

SilverStorm 9000 Multi-Protocol Fabric Director

10 Gb/s (SDR) and 20 Gb/s (DDR) Switching With Integrated Virtual I/O Controllers (VIC)

DATA SHEET

The SilverStorm 9000 family of Multi-Protocol Fabric Directors is the most highly integrated cluster computing interconnect solution available. An ideal solution for High Performance Computing (HPC), database clustering, and grid utility computing applications, the 9000 Fabric Directors are designed to maximize cluster and grid computing interconnect performance while simplifying and reducing the cost of operating a data center.

By leveraging the latest InfiniBand based technologies, the 9000 Fabric Director systems provide industry leading port densities, throughput performance, and ultra-low latency.

VIRTUAL I/O INTEGRATION

The 9000 family incorporates SilverStorm's innovative Virtual I/O Controller (VIC) technology. VIC modules installed in a 9000 system enable hosts on InfiniBand fabrics to transparently access either Fibre Channel or Ethernet networks or both. VIC modules utilize Virtual HBA and Virtual NIC technology creating a virtual pool of network and storage resource connectivity. VIC technology eliminates the cost and complexity of running multiple server physical connections for storage, network, and inter-processor communications, and allows each virtual network type to scale independently over a "single wire" connection.

FABRIC SCALABILITY

Most any cluster interconnect requirement can be supported economically when using 9000 series Fabric Directors. The family scales to support small networks with as few as 12 nodes using a single 1U chassis to multi-thousand node networks using multiple Fabric Director systems working in concert as a single high performance virtual fabric.

To allow for maximum fabric scalability, all SilverStorm 9000 systems utilize the same spine switching, leaf switching, and VIC option modules. All chassis types are slot-independent and each supports a flexible amount of switching capacity and port density depending on the number and type of option modules installed – as many as 432 ports and 11.52 Tb/s of switching throughput in a single chassis.

Slot Independent Chassis Options:

- 2 leaf slot 1U model 9020
- 4 leaf slot 4U model 9040
- 8 leaf slot 7U model 9080
- 12 leaf slot 7U model 9120
- 24 leaf slot 14U model 9240

Switching and VIC Module Options:

- 1.92Tb/s DDR spine switch
- 960Gb/s SDR spine switch
- 12 port 4x DDR leaf
- 12 port 4x SDR leaf
- 2 port 10Gb/s Ethernet, 10 port 4x DDR Virtual I/O Controller module
- 8 port 1/2/4 Fibre Channel, 10 port 4x DDR Virtual I/O Controller module

ADVANCED FEATURES

All major components are field replaceable and hot pluggable. Advanced features are supported, such as non-disruptive firmware upgrade, port-to-port and module-to-module failover, component level diagnostics and alarming, and both in-band and out-of-band remote management. When combined with SilverStorm's QuickSilver suite of fabric software solutions, the 9000 family of Fabric Directors supports the most demanding cluster computing interconnect requirements.



SILVERSTORM 9000

Strategic Benefits

- Significantly improve cluster computing application performance
- Eliminate the need for separate physical server connections to storage and network resources
- Scale servers and I/O independently
- Pool and share I/O between servers
- Simplify data center design and reduce operating costs
- Requires up to 1/3 less power and space than competitive solutions

Key Features

- Up to 11.52 Terabits of switching capacity in a single system
- Common set of spine, leaf, and Virtual I/O Controller modules across all chassis sizes
- 4x SDR/DDR InfiniBand, 1/2/4 Fibre Channel, and 10Gb/s Ethernet Virtual I/O interface options
- Fully redundant power, cooling, and logic components
- Up to 432 ports of Virtual I/O and 4x InfiniBand in a single chassis



SilverStorm 9000 Multi-Protocol Fabric Director

SilverStorm 9000 Specifications

Typical Cluster Interconnect

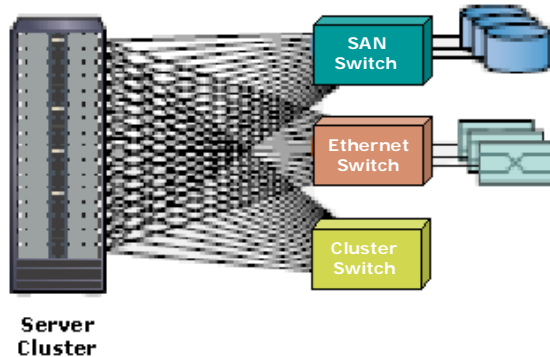

SilverStorm Interconnect

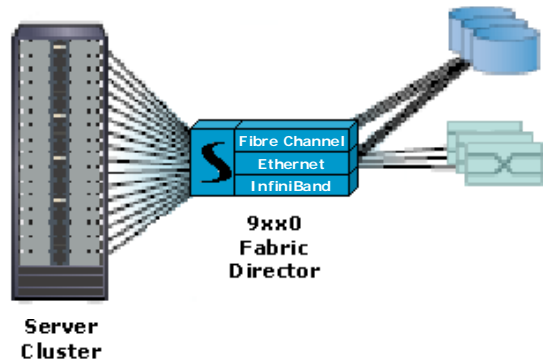

Chassis System Options

Model	Max # of Ports	System Capacity
9240	432	11.52 Tb/s
9120	216	5.76 Tb/s
9080	144	3.84 Tb/s
9040*	72	1.92 Tb/s
9020*	36	480 Gb/s

Leaf Module Options

Model	4x InfiniBand Ports	Virtual I/O Controller (VIC)
4x SDR IB	12	-
4x DDR IB	12	-
1/2/4 Fibre	10	8
10 Gb/s Ethernet	10	2

Physical Specifications

Model	Height	Width	Depth	Weight**
9240	24.5 in	17.32 in	25.5 in	180 lbs
9120	12.25 in	17.32 in	25.5 in	100 lbs
9080	12.25 in	17.32 in	25.5 in	90 lbs
9040*	7 in	17.32 in	25.5 in	55 lbs
9020*	1.75 in	17.32 in	25.5 in	32 lbs

* Check for availability

** Typical configuration

Management

- Optional redundant chassis management processor
- Optional embedded Fabric Management (SM, PM, and BM)
- Optional server-based InfiniBand compliant Subnet Manager
- SNMP management support

Environmental

- Temperature: Operating / (Non-Operating): 5° to 45°C / (-35° to 65°C)
- Humidity: Operating / (Non-Operating): 5 to 85% / (5 to 90%) non-condensing
- Power: 85 to 264 VAC (47-63 Hz), IEC 320 power connectors

Agency Compliance

- Safety: UL/CSA/EN
- EMI: FCC/VCCI/EN
- Marking: UL/GS/VCCI/CE /RoHS

InfiniBand Switch Modules

- Virtual Lanes: 8 plus 1 management
- MTU size: up to 4096
- Unicast table: 48K entries
- Multicast table: 1024 entries
- Switching latency: < 140 ns to < 420 ns

Fiber Channel VIC Module

- Supports up to 128 Virtual HBA ports per module
- Automatic sensing of port type: 1/2/4 Gb/s
- Automatic port and module fail-over
- Supports load balancing and port aggregation
- LUN mapping and masking features
- SCSI-SRP, SCSI-FCP, and FC-PH-3 compliant

Ethernet VIC Module

- Supports up to 1,150 Virtual NIC ports per module
- Automatic port and module fail-over
- Port load balancing and aggregation
- TCP/UDP and IP header checksum offload and host checking
- Jumbo frames supported
- 802.1Q VLAN support
- 802.1p Priority Queuing/Scheduling (802.1p)